



## Il sollevatore ULTRA SOTTILE

- **Tecnologia Multilink**
- **Nessuna modifica al veicolo**
- **Portata 300 kg**

PATENT PENDING



### NESSUNA MODIFICA AL VEICOLO

- Serbatoio originale
- Impianto di scarico originale Euro 6
- Nessuna modifica strutturale richiesta
- Installabile su Mercedes Classe V e Volkswagen T5/T6

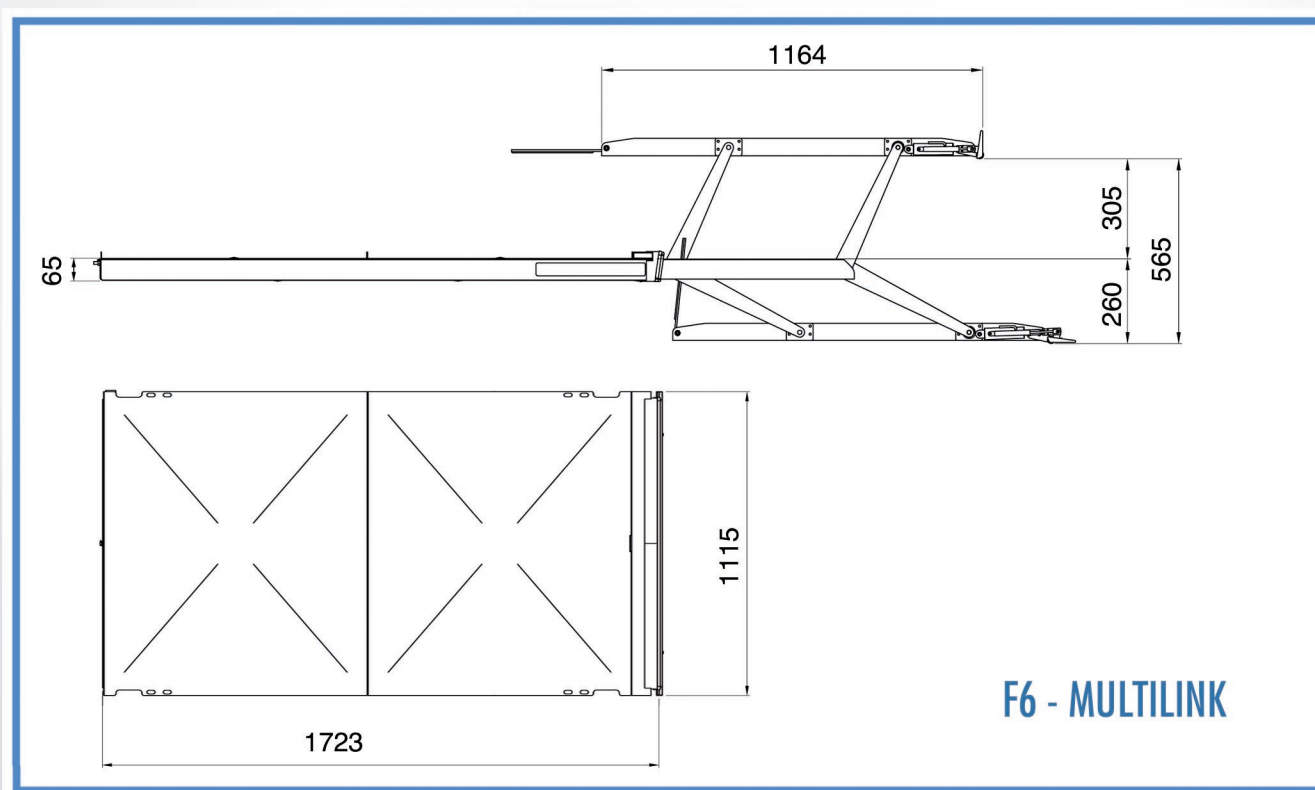

F6 - MULTILINK

### Caratteristiche tecniche

Modello	F6 Multilink
Portata	300 kg
Peso	140 kg
Piattaforma	760 x 1160 mm
Pompa manuale d'emergenza e valvola di discesa	